

## Micro thin film thermistor

# FT Thermistor

FT thermistors have outclassed conventional thermistors through miniaturization, featuring quick response time, high heat resistance and excellent long term reliability.

### Product number explanation

103	FT	1005	A	5P	1	-	□
<p>T: Taping<sup>1</sup>                  No marking: Untaped bulk products                  Electrode type: 1 = Pt                                    2 = Au/Ni                                    3 = Au                  Tolerance (R<sub>25</sub>): 5P = 5%                  B value: A = 3370 K                            B = 3435 K                            D = 3969 K                  Size: See Fig. 1                  Micro thin film thermistor                  Rated zero-power resistance at 25 °C                  E.g.: 103 = 10 x 10<sup>3</sup> Ω</p>							

<sup>1</sup>: Taping is currently available only for 1005 size.

### Applications

High speed electrical thermometers, wearable devices, office automation, measurement instruments, medical devices, computer and mobile devices, LCDs, security devices, laser diode modules

### Dimensions

Fig. 1

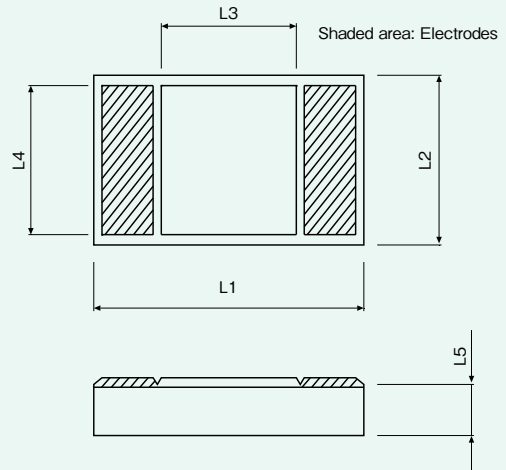

Size	L1	L2	L3	L4	L5 <sup>2</sup>
1005	1.00 ± 0.05	0.50 ± 0.05	(0.50)	(0.44)	(0.15)
0603	0.60 ± 0.05	0.30 ± 0.05	(0.15)	(0.25)	(0.15)

Unit: mm

<sup>2</sup>: For thinner substrates (= smaller L5 dimension) please contact SEMITEC sales staff.

### Specifications

Product number	R <sub>25</sub> <sup>3</sup>	R <sub>25</sub> tolerance	B value <sup>4</sup>	Dissipation factor (mw / °C)	Thermal time constant (s) <sup>5</sup>	Rated power at 25 °C (mW)	Operating temperature range by electrode (°C)		
							1: Pt	2: Au/Ni	3: Au
103FT1005A5P	10.0 kΩ	± 5% <sup>6</sup>	3370 K ± 1%	approx. 0.3	approx. 1.0	1.5	- 40 to 250 (350)	- 40 to 125	- 40 to 250
103FT1005B5P	10.0 kΩ		3435 K ± 1%						
103FT1005D5P	10.0 kΩ		3969 K ± 1%						
503FT1005A5P	50.0 kΩ		3370 K ± 1%						
503FT1005B5P	50.0 kΩ		3435 K ± 1%						
364FT1005A5P	360.0 kΩ		3370 K ± 1%						
<b>New</b> 364FT0603A5P	360.0 kΩ		3370 K ± 1%	approx. 0.2	approx. 0.5	1.0			

<sup>3</sup>: Rated zero-power resistance at 25 °C    <sup>4</sup>: B value calculated from rated zero-power resistance at 25 °C and 85 °C

<sup>5</sup>: Time required to reach 63.2% of temperature difference. Measured with sensor suspended in mid-air.

<sup>6</sup>: If your application requires other tolerance values please contact SEMITEC sales staff.

### Reliability data

Item	Electrode type	Test conditions	Criteria
Solderability	2 = Au/Ni	5 s at 260 °C	More than 90% soldered
Free fall	All	Three times natural fall to a maple board from 0.75 m height.	ΔR, ΔB ± 1%
Insulation resistance	All	100 V DC	Over 100 MΩ
Dry heat (1)	1 = Pt 3 = Au	1000 hours at 250 °C	ΔR ± 5%, ΔB ± 1%
Dry heat (2)	2 = Au/Ni	1000 hours at 125 °C	ΔR ± 3%, ΔB ± 1%
Cold	All	1000 hours at - 40 °C	ΔR ± 3%, ΔB ± 1%
Temperature cycle (thermal shock)	All	100 cycles as below: 1. - 40 °C for 30 minutes 2. Room temperature for 3 minutes 3. 125 °C for 30 minutes 4. Room temperature for 3 minutes	ΔR ± 3%, ΔB ± 1%

### Mounting method recommendations

Electrode type	Recommended method
1 = Pt	Conductive resin
2 = Au/Ni	Solder
3 = Au	Wire bonding

## ■ Resistance / temperature characteristics

Temperature (°C)	Product number						
	103FT1005A5P	103FT1005B5P	103FT1005D5P	503FT1005A5P	503FT1005B5P	364FT1005A5P	364FT0603A5P
-40	187.9	200.7	351.0	939.3	1,002	6,763	6,763
-30	110.7	117.0	185.0	553.4	584.7	3,984	3,984
-20	67.26	70.34	100.9	336.3	351.9	2,421	2,421
-10	42.10	43.55	57.00	210.5	217.7	1,516	1,516
0	27.08	27.71	33.33	135.4	138.5	974.8	974.8
10	17.86	18.11	20.12	89.31	90.48	643.0	643.0
20	12.07	12.12	12.53	60.33	60.58	434.4	434.4
25	10.00	10.00	10.00	50.00	50.00	360.0	360.0
30	8.332	8.299	8.038	41.66	41.50	299.9	299.9
40	5.871	5.804	5.295	29.36	29.03	211.4	211.4
50	4.216	4.139	3.575	21.08	20.70	151.8	151.8
60	3.081	3.006	2.472	15.40	15.04	110.9	110.9
70	2.288	2.220	1.746	11.44	11.11	82.36	82.36
80	1.725	1.666	1.258	8.623	8.331	62.09	62.09
85	1.505	1.451	1.075	7.527	7.257	54.19	54.19
90	1.318	1.269	0.9230	6.592	6.344	47.46	47.46
100	1.021	0.9797	0.6888	5.105	4.898	36.76	36.76
110	0.8003	0.7662	0.5220	4.002	3.829	28.81	28.81
120	0.6345	0.6064	0.4012	3.172	3.029	22.84	22.84
125	0.5671	0.5418	0.3535	2.836	2.706	20.42	20.42
130	0.5084	0.4854	0.3125	2.542	2.423	18.30	18.30
140	0.4113	0.3926	0.2465	2.057	1.960	14.81	14.81
150	0.3359	0.3207	0.1969	1.680	1.601	12.09	12.09
160						9.963	9.963
170						8.274	8.274
180						6.925	6.925
190						5.837	5.837
200						4.954	4.954
210						4.232	4.232
220						3.636	3.636
230						3.142	3.142
240						2.731	2.731
250						2.385	2.385
B <sub>25/85</sub>	3370 K	3435 K	3969 K	3370 K	3435 K	3370 K	3370 K

Unit: kΩ

## ■ Taping dimensions

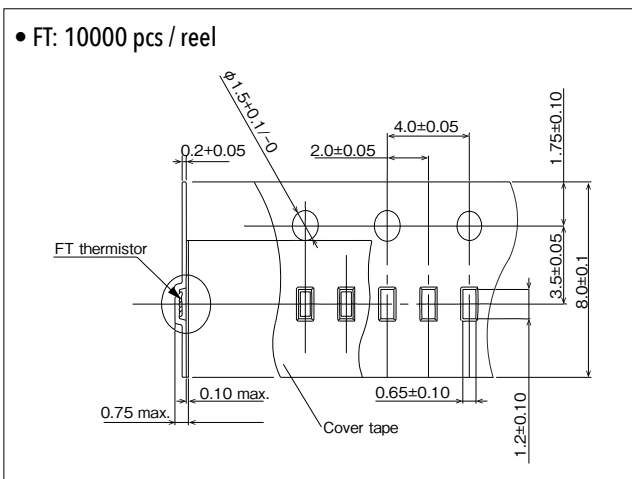

## ■ How to use the FT thermistor

- The FT thermistor can be used for both SMD type mounting and as a leaded thermistor (both axial and radial).  
If your application requires lead wires please contact SEMITEC sales staff
- With the FT thermistor it is possible to pair two sensors (e.g. one for temperature measurement and one for compensation) with very high accuracy. If your application may require thermistor pairing please contact SEMITEC sales staff.

## ■ Caution

- Please contact us when choosing the mounting method.
- Please contact us when considering an application with an environment temperature exceeding 350 °C.

## ■ Recommended mounting pad dimensions

